

# CONTROL AUTOMATION



## LOCAL EXTRACTORS

**Fumex control automation helps create good working environments, adapted to all types of installations. The right choice of control also conserves considerable energy and provides the lowest possible noise levels.**

Control automation encompasses specially adapted and proven components, as well as recommendations for appropriate system selections. In the installation examples on pages 2 through 5, there are suggestions for various solutions to help in finding systems to satisfy most needs. Local extraction arms are presented in various system solutions in the examples. Automation can even be used in other applications, such as when connecting extractors directly to machinery. For control of automotive exhaust installations, see the control automation for exhaust extraction. Most types of sensors – such as for gas, heat, light and vibrations – can be combined with the S 200 and S 400 control units. For help in optimising extractor installations or calculating energy savings, please contact Fumex.

*The Fumex assortment also includes local extractors, fans, accessories and filters.*

# FUMEX®

LOCAL EXTRACTORS

**pure advantage**

# Starting and stopping fans, with or without speed control

## System 1:1

### Manual starting and stopping of fan

The fan is manually started and stopped with motor protection circuit-breaker SMB.

The motor protection circuit-breaker features thermal-magnetic disconnection and phase failure protection.

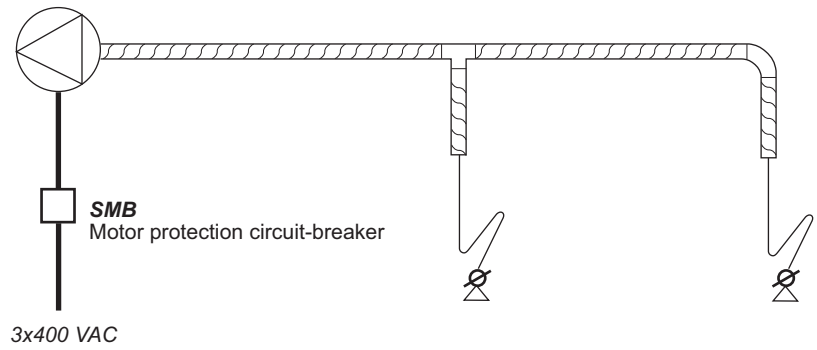

## System 1:2

### Manual speed control of fan that is started and stopped with external signal

The signal for starting and stopping the fan is produced with an external signal from, for example, a central monitoring system.

The fans speed is regulated manually as necessary with the SFC POT potentiometer.

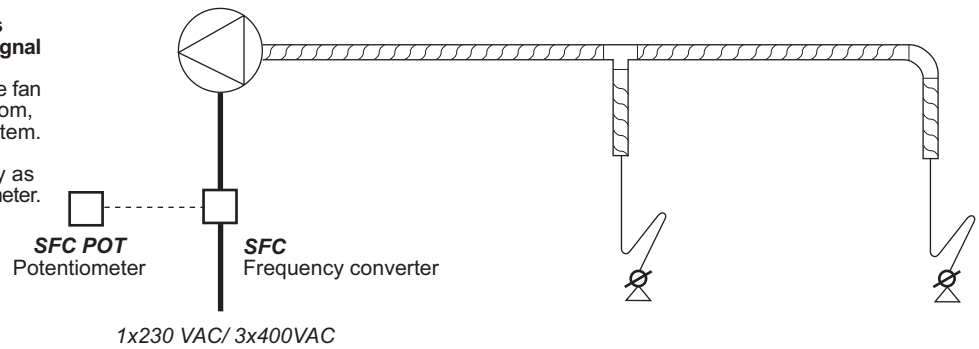

## System 1:3

### Manual starting and stopping of fan, and two speeds

The fan is manually started and stopped with the SFC VSS rotary switch.

With the rotary switch, the fan speed can be regulated between two preset speeds that are programmed on the frequency converter display.

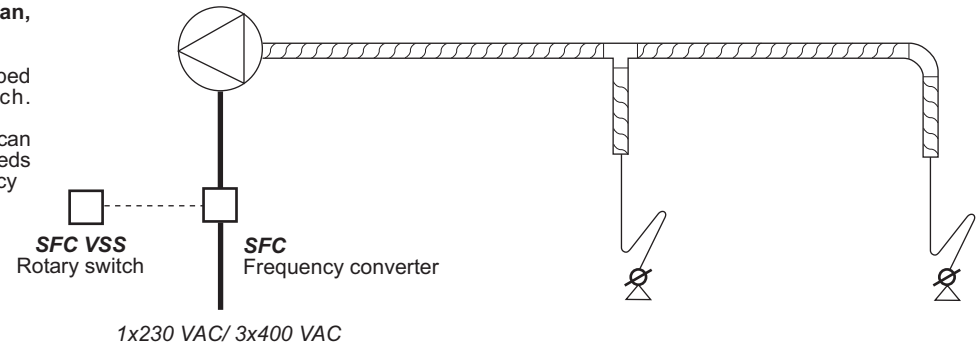

## System 1:4

### Manual starting and stopping of fan, and need-adapted control of fan speed

The fan is manually started and stopped with the SFC SB switch.

The frequency converter maintains a constant negative pressure in the branch duct via the pressure sensor.

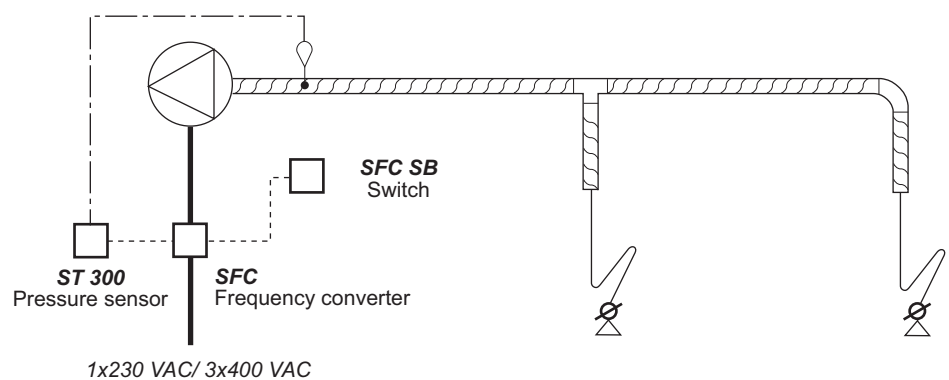

— 1x230/ 3x400 VAC  
 - - - - - Signal cable  
 - - - - - Hose

# Starting and stopping fans with contactors

## Manual control from work station without time delay

### System 2:1 Manuel starting and stopping of fan.

Starting and stopping are conducted manually with a button mounted on the extractor.

The system with control directly via the junction box does not permit automatic control with a clip-on sensor nor time delay with a timer card.

\* Mechanical timer SMT 60 can be replaced with the KHT 600 button unit. This a suitable solution for schools, for example.

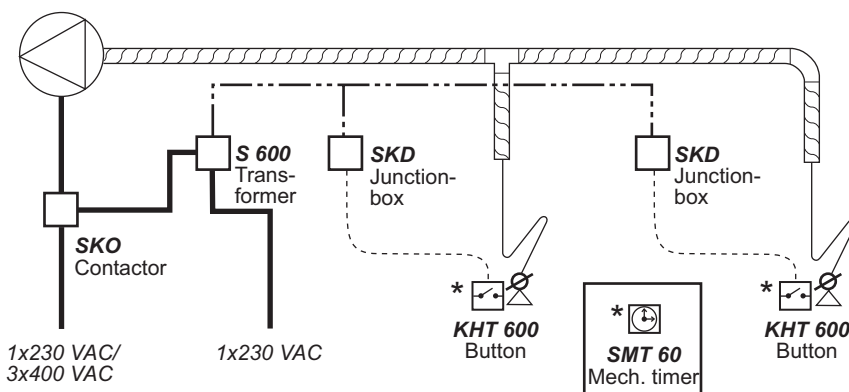

## Manual control from work station with time delay

### System 2:2 Manuel starting and stopping of fan.

Starting and stopping are conducted manually with a button mounted on the extractor.

The S 400 control unit features an adjustable time delay of 0 - 15 minutes.

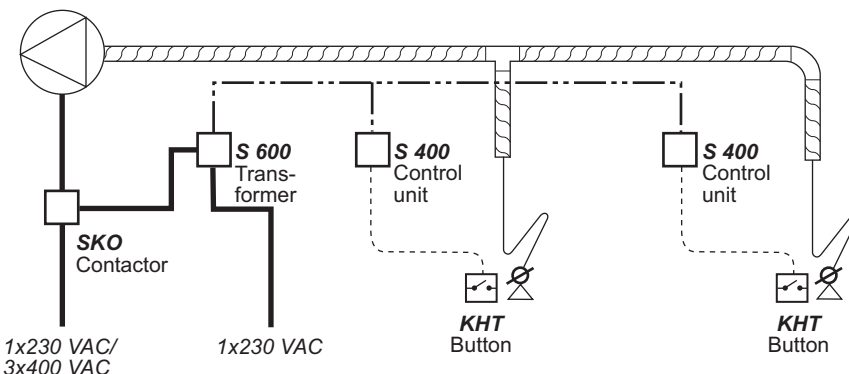

## Automatic control from work station with time delay.

### System 2:3 Automatic starting and stopping of fan.

Starting and stopping are conducted automatically with the STG 400 clip-on sensor, which is clipped onto the earth cable of the welding transformer.

The S 400 control unit features an adjustable time delay of 0-15 minutes.

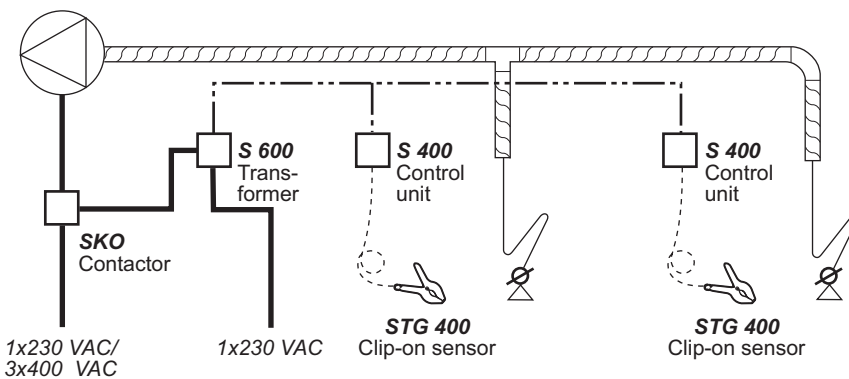

— 1x230/ 3x400 VAC  
 - - - 24 VAC  
 ····· Signal cable

# Individual damper control, and starting and stopping of fan via contactor

## Damper and contactor manually controlled from the work station without time delay

### System 3:1 Manual control of damper, and starting and stopping of fan

The damper is opened and closed manually with a 2-pole switch mounted on the extractor, which also starts and stops the fan.

The system with control directly via the junction box does not permit automatic control with a clip-on sensor nor time delay with a timer card.

\* Mechanical timer SMT 60 can be replaced with the KHT 600 button unit. This is a suitable solution for schools, for example.

The SMT 60 is wall mounted.

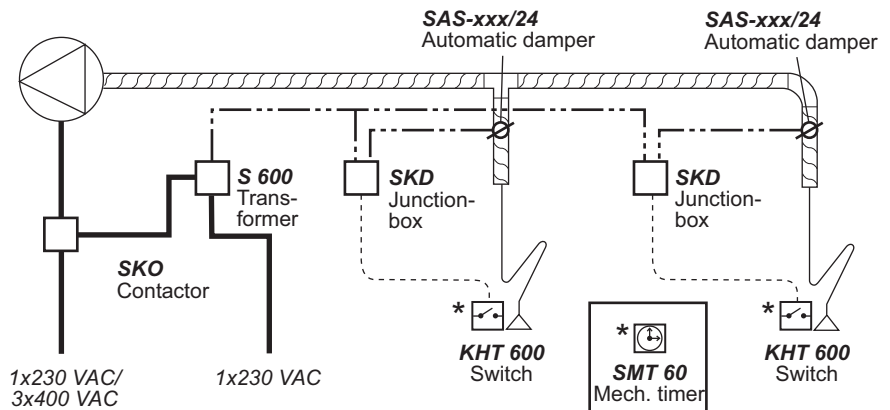

## Damper and contactor manually controlled from the work station with time delay

### System 3:2 Manual control of damper, and starting and stopping of fan

Opening and closing of the damper are conducted manually with a button mounted on the extractor.

A control signal from the control unit starts and stops the fan.

The S 400 control unit features an adjustable time delay of 0–15 minutes.

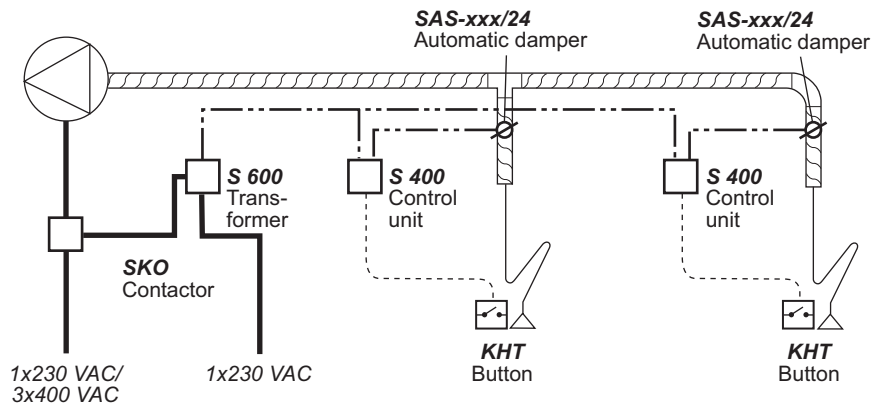

## Damper and contactor automatically controlled from the work station with time lag

### System 3:3 Automatic control of damper, and starting and stopping of fan

The damper is opened and closed automatically with the STG 400 clip-on sensor, which is clipped onto the earth cable of the welding transformer.

A control signal from the control unit starts and stops the fan.

The S 400 control unit features an adjustable time delay of 0–15 minutes.

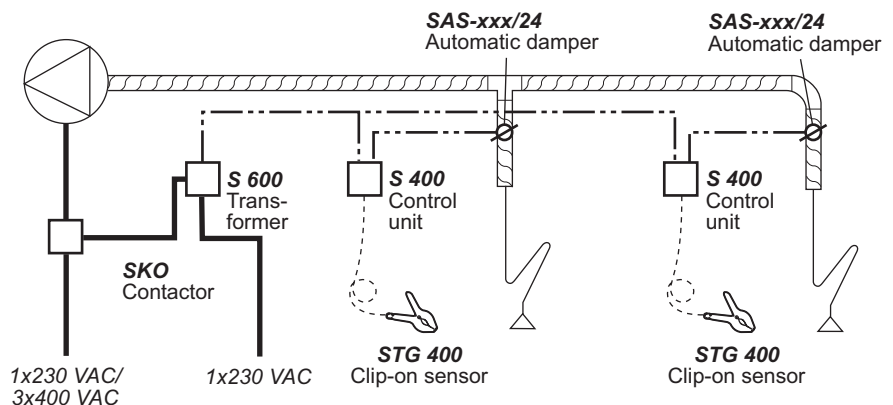

— 1x230/ 3x400 VAC  
 - - - 24 VAC  
 ····· Signal cable

# Individual damper control and need-adapted control of fan via a pressure sensor and frequency converter

## Damper and frequency converter manually controlled from the work station without time delay

### System 4:1

#### Manual control of damper, and need-adapted control and starting and stopping of fan

The damper is opened and closed manually with a 2-pole switch mounted on the extractor, which also starts and stops the fan.

The frequency converter maintains a constant negative pressure in the branch duct via the pressure sensor.

The system with control directly via the junction box does not permit automatic control with a clip-on sensor nor time-delay with a timer card.

\* Mechanical timer SMT 60 can be replaced with the KHT 600 switch.

This is a suitable solution for schools, for example. The SMT 60 is wall mounted.

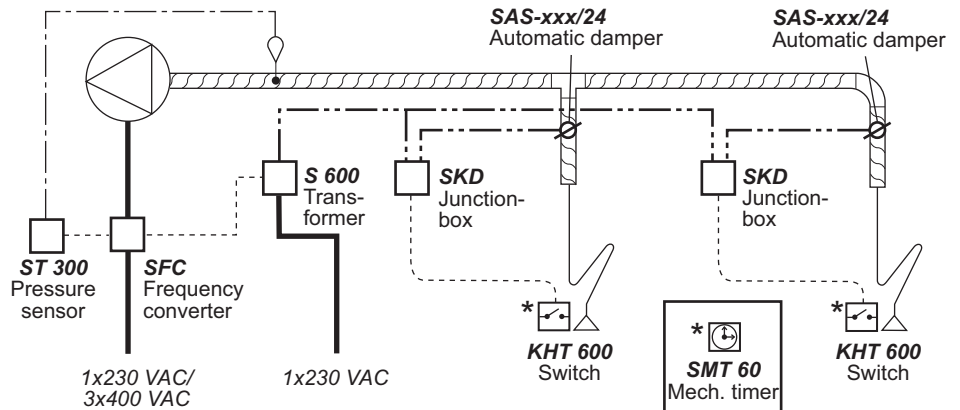

## Damper and frequency converter manually controlled from the work station with time delay

### System 4:2

#### Manual control of damper, and need-adapted control and starting and stopping of fan

The damper is opened and closed manually with a button mounted on the extractor, which also starts and stops the fan.

The frequency converter maintains a constant negative pressure in the branch duct via the pressure sensor.

The S 400 control unit features an adjustable time delay of 0–15 minutes.

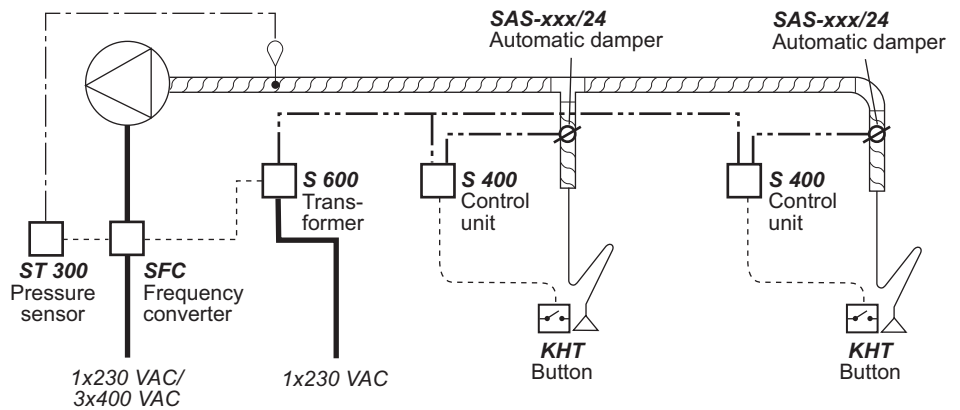

## Damper and frequency converter automatically controlled from the work station with time delay

### System 4:3

#### Automatic control of damper, and need-adapted control and starting and stopping of fan

The damper is opened and closed automatically with the STG 400 clip-on sensor, which is clipped onto the earth cable of the welding transformer.

A control signal from the control unit starts and stops the fan.

The frequency converter maintains a constant negative pressure in the branch duct via the pressure sensor.

The S 400 control unit features an adjustable time delay of 0–15 minutes.

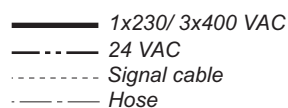
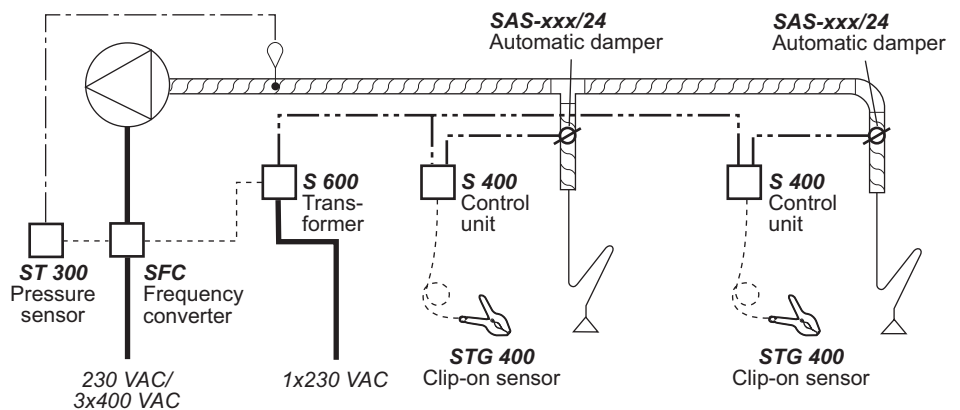



## FREQUENCY CONVERTER Designed for process ventilation

The SFC frequency converter was designed for stepless speed control of among other things, fans. This provides optimal operating economy and the lowest possible noise level. Depending on the number of work stations in operation, the SFC (along with the ST 300 pressure sensor) varies fan speeds, consequently evacuating the correct amount of air. Alternatively, manual stepless control can be employed with the SFC POT potentiometer. The SFC VSS is used if 2-step control is preferred.

Interference filters are included. The enclosure class is IP 21 for built-in applications, alternatively IP 55 for dust and water protection.

Fumex can supply SFC PROG pre-programmed frequency converters to make it easier to put systems in operation.

*For alternative voltages, etc., please contact Fumex.*

### ENCLOSURE CLASS IP 21

Designation	Rated power kW	Rated current A	Voltage V	Weight kg	Width mm	Height mm	Depth mm
SFC 037/21-1 SFC 037/21-3	0,37 0,37	3,3 1,5	230 400	1,5 1,8	72 105	145 143	130 150
SFC 055/21-1 SFC 055/21-3	0,55 0,55	3,7 1,9	230 400	1,5 1,8	72 105	145 143	140 150
SFC 075/21-1 SFC 075/21-3	0,75 0,75	4,8 2,3	230 400	1,5 1,8	72 105	145 143	140 150
SFC 110/21-1 SFC 110/21-3	1,1 1,1	6,9 3	230 400	1,8 1,8	105 105	143 143	150 150
SFC 150/21-1 SFC 150/21-3	1,5 1,5	8 4,1	230 400	1,8 1,8	105 105	143 143	150 150
SFC 220/21-1 SFC 220/21-3	2,2 2,2	11 5,5	230 400	3,1 3,1	140 140	184 184	150 150
SFC 400/21-3	4	9,5	400	3,1	140	184	150
SFC 750/21-3	7,5	17	400	6,5	180	232	170

### ENCLOSURE CLASS IP 55

Designation	Rated power kW	Rated current A	Voltage V	Weight kg	Width mm	Height mm	Depth mm
SFC 037/55-1 SFC 037/55-3	0,37 0,37	3,3 1,5	230 400	6,3 8,8	210 215	240 297	163 192
SFC 055/55-1 SFC 055/55-3	0,55 0,55	3,7 1,9	230 400	6,3 8,8	210 215	240 297	163 192
SFC 075/55-1 SFC 075/55-3	0,75 0,75	4,8 2,3	230 400	6,3 8,8	210 215	240 297	163 192
SFC 110/55-1 SFC 110/55-3	1,1 1,1	6,9 3	230 400	8,8 8,8	215 215	297 297	192 192
SFC 150/55-1 SFC 150/55-3	1,5 1,5	8 4,1	230 400	8,8 8,8	215 215	297 297	192 192
SFC 220/55-1 SFC 220/55-3	2,2 2,2	11 5,5	230 400	10,7 10,7	230 230	340 340	208 208
SFC 400/55-3	4	9,5	400	10,7	230	340	208
SFC 750/55-3	7,5	17	400	23,6	320	425	290

# SFC POT/VSS/SB



## SFC POT POTENTIOMETER

The SFC POT is a potentiometer for stepless regulation of fan speeds via frequency converters.

**Dimensions** 100x100x67 mm  
**Resistance** 10 k $\Omega$

## SFC VSS ROTARY SWITCH

The SFC POT is a rotary switch for 2-step regulation of fan speeds via frequency converters.

**Dimensions** 100x100x67 mm  
**Increments** 0-1-2

## SFC SB SWITCH

The SFC SB is a switch for starting/stopping fans via frequency converters.

**Dimensions** 60x80x55 mm  
**Enclosure class** IP 54  
**Power supply** Max 250 V, 16 A

# ST 300



## ST 300 PRESSURE SENSOR

The ST 300 maintains constant negative pressure in the discharge duct via a frequency converter that controls fan speeds. The ST 300 always provides the correct flow, regardless of the number of open and closed dampers.

**Dimensions** 90x96x36 mm  
**Enclosure class** IP 54  
**Operating range** 500, 1000, 2000, 3000 Pa  
**Power supply** 24 VDC  
**Output signal** 0-10 V (alt. 4-20 mA)  
**Included accessories** Measurement output and 2 m hose

# S 200/230

## S 200/230 CONTROL UNIT

The S 200/230 is used for automatic control of damper motor SAS 230 and/or a fan. The after-run time for evacuation of remaining gases is built into the clip-on sensor (~30 sec.). For longer after-run times, there is an adjustable timer card (0–15 min. and 0–240 min.) available as an accessory. Single-phase fans (max. 0.75 kW) can be directly controlled via an integrated relay. Other fans are controlled with an external contactor via the same integrated relay, terminals 1–5. Frequency converters are controlled via the potential-free output, terminals 6–8.

<b>Dimensions</b>	180x130x77 mm
<b>Enclosure class</b>	IP 54
<b>Primary side</b>	230 VAC
<b>Secondary side</b>	230 VAC (Max 10A)

### ACCESSORIES

<b>STK 15</b>	Timer card 0-15 min
<b>STK 240</b>	Timer card 0-240 min
<b>SSB</b>	Switch
<b>STG 200</b>	Clip-on sensor (~30s fördröjning)
<b>KHT</b>	Button unit

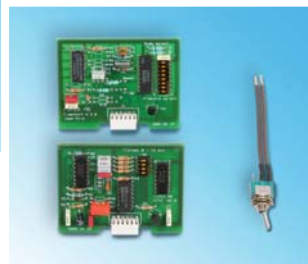

# S 200/24

## S 200/24 CONTROL UNIT

The S 200/24 is used for automatic control of damper motor SAS 24 and/or a fan. The after-run time for evacuation of remaining gases is built into the clip-on sensor (~30 sec.). For longer after-run times, there is an adjustable timer card (0–15 min. and 0–240 min.) available as an accessory. Fans are controlled with external contactors via the integrated relay, terminals 1–5. Frequency converters are controlled via the potential-free output, terminals 6–8.

<b>Dimensions</b>	180x130x77 mm
<b>Enclosure class</b>	IP 54
<b>Primary side</b>	230 VAC
<b>Secondary side</b>	230 VAC

### ACCESSORIES

<b>STK 15</b>	Timer card 0-15 min
<b>STK 240</b>	Timer card 0-240 min
<b>SSB</b>	Switch
<b>STG 200</b>	Clip-on sensor (~30s fördröjning)
<b>KHT</b>	Button unit

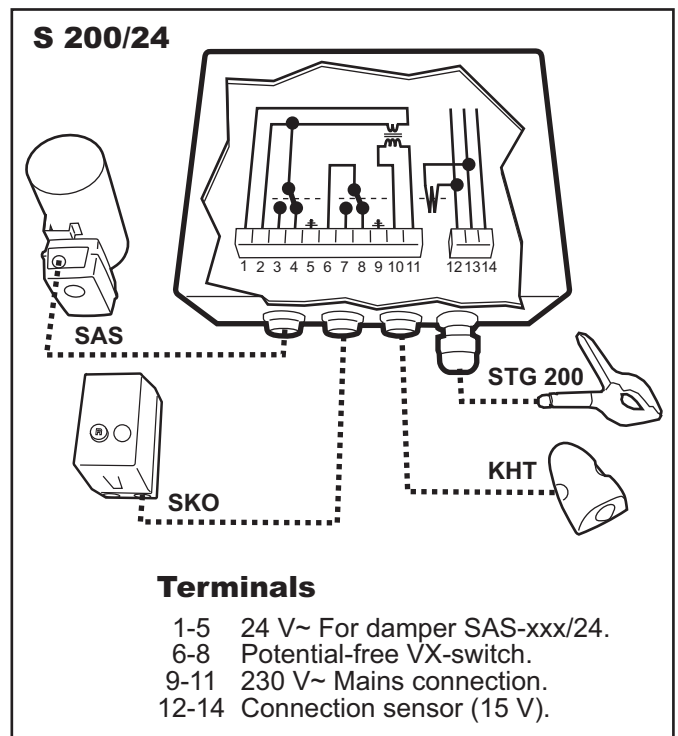
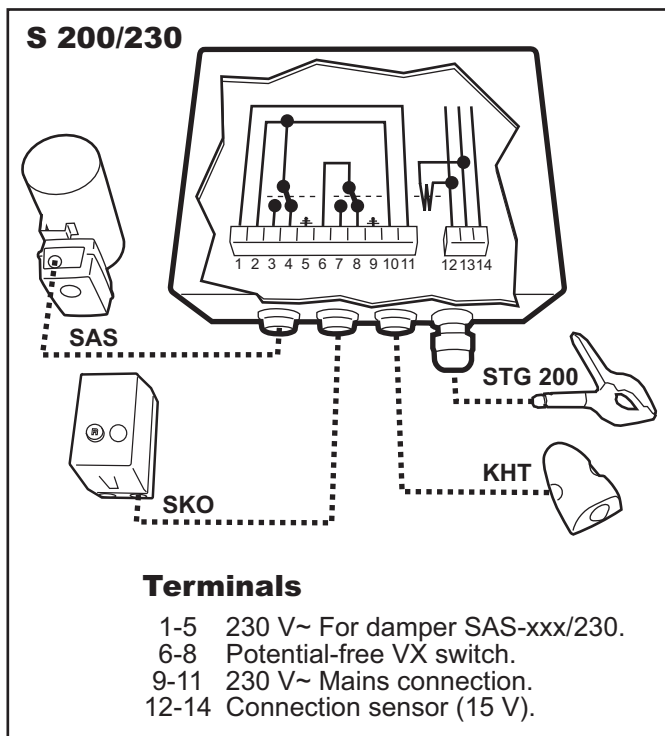

## S 400 CONTROL UNIT

The S 400 is used for automatic control of damper motor SAS 24 at terminals 1–4. Fans are normally controlled via the S 600 transformer units. The after-run time for evacuation of remaining gases is built into the control unit. The time is set between 0–15 min. The S 400 is supplied with 24 VAC from the S 600 transformer unit.

<b>Dimensions</b>	130x80x77 mm
<b>Enclosure class</b>	IP 54
<b>Primary side</b>	24 VAC
<b>Secondary side</b>	24 VAC

### ACCESSORIES

<b>SSB</b>	Switch
<b>STG 400</b>	Clip-on sensor
<b>KHT</b>	Button unit



## S 400

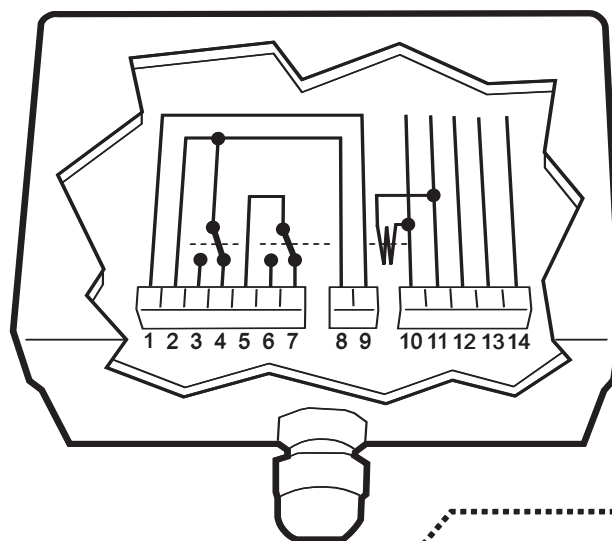

### Terminals

- 1-4 24 V~ For damper SAS-xxx/24.
- 5-7 Potential-free VX-switch.
- 8-9 24 V~ supply from S 600.
- 10-14 Connection sensor (15 V).

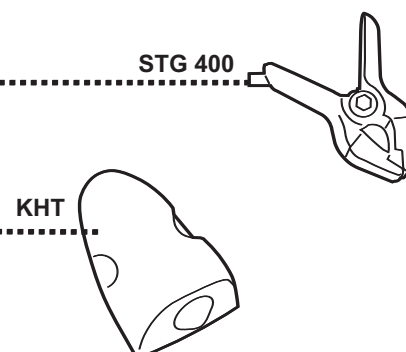
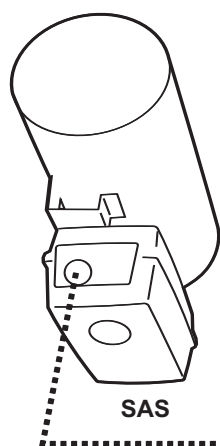

# S 600

## S 600 TRANSFORMER UNIT

The S 600 is used to supply 24 VAC to the S 400 control unit. Fan control is via 230-VAC external contactors with signalling from terminals 1 and 2. Frequency converters are controlled via the potential-free outputs, terminals 3 and 4. The S 600 can also be used in a custom system with the SKD junction box. The SKD distributes power to dampers and to the KHT 600 for automatic starting/stopping of fans, as well as automatic opening of SAS dampers.

**Dimensions** 130x180x102 mm  
**Enclosure class** IP 54  
**Primary side** 230 VAC  
**Secondary side** 24 VAC (60 VA)

## SMT 60 TIMER SWITCH

The SMT mechanical timer switch is a manual timer, adjustable from 0 to 60 minutes. It can be replaced by a KHT button unit. The SMT 60 is wall-mounted close to the extractor.

**Dimensions** 100x100x67 mm  
**Times** 0 - 60 min.

## ACCESSORIES

**SKD** Junction box  
**KHT 600** Button unit  
**SMT 60** Mechanical timer switch, 1 h

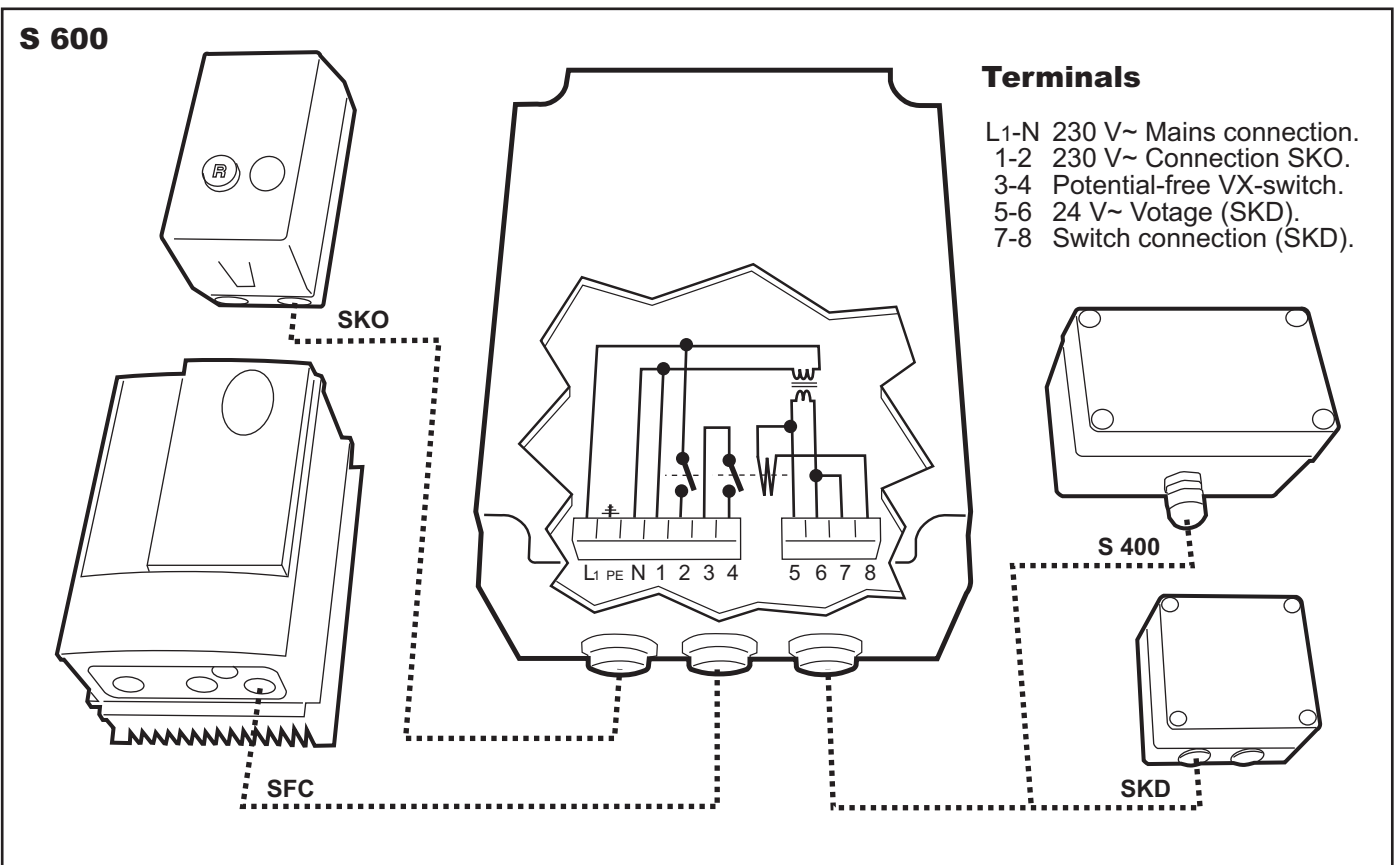

# SMB



## SMB MOTOR PROTECTION CIRCUIT-BREAKER

The SMB is a 3-pole motor protection circuit-breaker with thermal-magnetic disconnection and equipped with phase failure protection. The SMB is designed for control and protection of fan motors.

**Dimensions** 93x148x84 mm  
**Enclosure class** IP 55

Product	Current range (A)	3-phase ~400 V (kW)
SMB 10*	0,63-1,0	0,25
SMB 16*	1,0-1,6	0,37/0,55
SMB 25*	1,6-2,5	0,75
SMB 40*	2,5-4,0	1,1/1,5
SMB 63*	4,0-6,3	2,2
SMB 100*	6,0-10,0	4,0
SMB 140**	9,0-14,0	5,5
SMB 180**	13,0-18,0	7,5

\* Self-protecting, pre-fusing not required

\*\* Max. pre-fusing when  $I_k > I_{cu}$  is 63 A.

# SKO



## SKO CONTACTOR

The SKO is a 3-pole contactor with an overcurrent relay for manual resetting. The overcurrent relay has phase failure protection. It is used with external switches or control.

**Dimensions** 103x200x153 mm  
**Enclosure class** IP 55

Product	Current range (A)	3-phase ~400 V (kW)
SKO 10/230*	0,63-1,0	0,25
SKO 17/230*	1,0-1,6	0,37/0,55
SKO 25/230*	1,6-2,5	0,75
SKO 40/230*	2,5-4,0	1,1/1,5
SKO 60/230*	4,0-6,3	2,2
SKO 80/230*	6,0-10,0	4,0
SKO 130/230**	9,0-14,0	5,5
SKO 180/230**	13,0-18,0	7,5

\* Maximum power is 4 kW.

\*\*Maximum power is 7.5 kW.

~24 V



## SAS AUTOMATIC DAMPER

The SAS is an automatic single-leaf damper for applications where short operating times are necessary.

The extremely fast motor opens the damper blade in 7.5 seconds. This entails 95% extraction capacity after 3 seconds.

The damper is supplied for air tightness class 1. For other air tightness classes, please contact Fumex.

<b>Dimensions (motor)</b>	140x100x85 mm
<b>Material (cowling)</b>	PA
<b>Material (damper housing)</b>	Galvaniserad plåt
<b>Opening time, 90°</b>	7,5 s
<b>Torque</b>	3 Nm
<b>Power consumption (24 V)</b>	2 VA i drift/ 0 VA i vila
<b>Power consumption (230 V)</b>	5 VA i drift/ 0 VA i vila

Product	Diameter (mm)	Voltage (V)
SAS-100/24	Ø100	24
SAS-125/24	Ø125	24
SAS-160/24	Ø160	24
SAS-200/24	Ø200	24
SAS-250/24	Ø250	24
SAS-315/24	Ø315	24
SAS-100/230	Ø100	230
SAS-125/230	Ø125	230
SAS-160/230	Ø160	230
SAS-200/230	Ø200	230
SAS-250/230	Ø250	230
SAS-315/230	Ø315	230

~230 V

