



Flextraction Limited
10 Digby Drive · Melton Mowbray · Leicestershire · LE130RQ
Tel: +44 (0) 1664 410641 · Fax: +44 (0) 1664 480244
E-mail: sales@flextraction.co.uk
www.flextraction.co.uk

DOWNDRAUGHT BENCH FB2000



DOWNDRAUGHT BENCH FB2000



Flextraction Limited
 10 Digby Drive · Melton Mowbray · Leicestershire · LE130RQ
 Tel: +44 (0) 1664 410641 · Fax: +44 (0) 1664 480244
 E-mail: sales@flextraction.co.uk
 www.flextraction.co.uk

The FB2000 downdraught filter bench is designed for light dust applications such as grinding, fettling, de-burring etc and is available in standing or seated configurations.

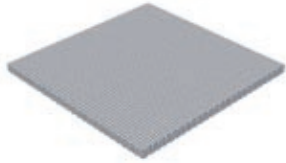

Aluminium mesh filter
 Used in conjunction with spark arrestor (optional)

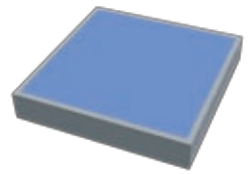

Pre-filter
 G4 Pleated pre filter to remove particulate

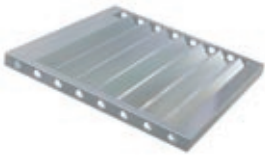

Spark arrestor
 For grinding applications (optional)

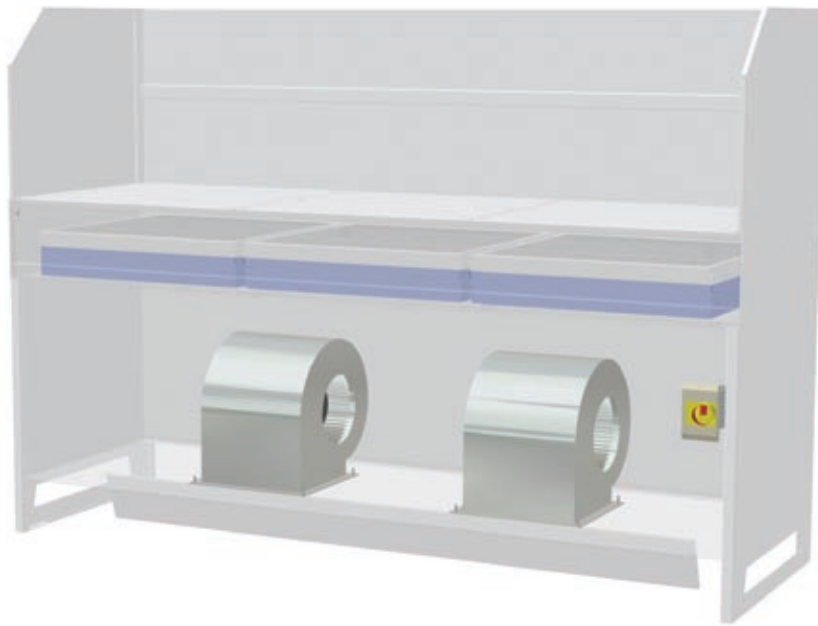

Manual Motor Starter
 Starter and overload combined in one switch for ease of wiring



Fan
 2 x 600w high power centrifugal fans.
 Running current 13.6A (max)
 230v 50/60Hz 1pH

TECHNICAL DATA

Air Volume (max)	6000m ³ h (free blowing)
Velocity	2.0m/s (clean filter)
Motor rating	600w (x2)
Current (max)	6.8A (x2)
Supply	230v 50/60Hz 1pH
Weight	220Kg

FINISH

- RAL 7035
- Wide range of other colours available
- Built to CE Standards
- Bespoke sizes are available

DIMENSIONS

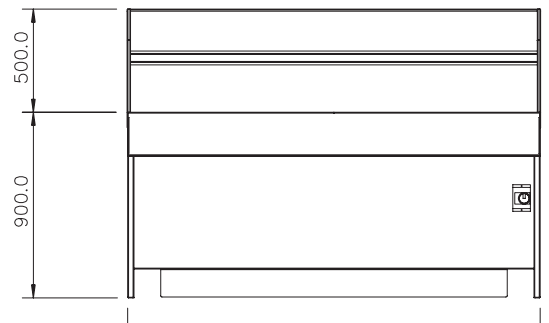
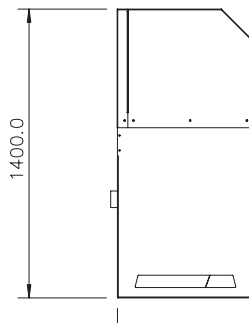

DOWNDRAUGHT BENCH FB2000